

# RM 500

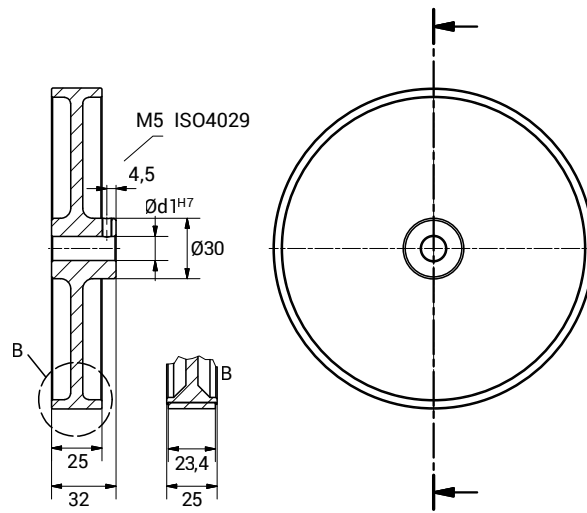

## CHARACTERISTICS

- Measuring wheels made of aluminum with different running surface (smooth, knobbed, ribbed or cross-knurlled surface) suitable for linear measurement of a wide range of materials.
- Thanks to the very good concentricity property it is possible to obtain the maximum measuring accuracy also with high speed.

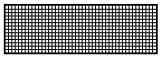
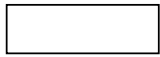
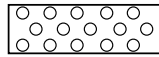
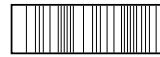

TECHNICAL DATA		RMAR 500	RMAP500	RMAN 500	RMAG 500
Material core		Aluminium	Aluminium	Aluminium	Aluminium
Material surface		Aluminium	Polyurethane	Polyurethane	Polyurethane
Surface structure		Cross-hatched knurling	Smooth	Studded	Corrugated
Profile					
Circumference	mm.	500±0,2	500±0,2	500±0,2	500±0,2
Moment of inertia	gcm <sup>2</sup>	17,1x10 <sup>3</sup>	15,3x10 <sup>3</sup>	15,5x10 <sup>3</sup>	15,2x10 <sup>3</sup>
Weight	gr.	505	501	483	501
Application fields		Cardboard, wood, textile, rubber, soft plastic	Steel profile, painted surface, plastic, cardboard, wood, textiles, wire, leather	Raw fabrics, cable gauge, cardboard, wood, plastic	Painted surface, plastic, cardboard, wood, textiles, glass

## STANDARD HOLES

6 - 8 - 10 - 12