

# RM 152

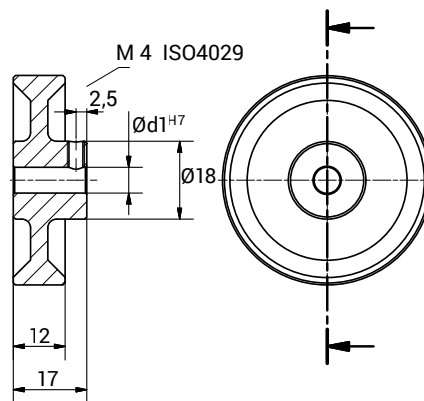

## CHARACTERISTICS

- Measuring wheel, cross-hatched, knurling surface.



TECHNICAL DATA	
Material core	Aluminium
Material surface	Aluminium
Surface structure	Cross-hatched knurling
Profile	
Circumference	mm. 152,4±0,2
Moment of inertia	gcm <sup>2</sup> 0,11x10 <sup>3</sup>
Weight	gr. 60
Application fields	Cardboard, wood, textiles, rubber

STANDARD HOLES
4 - 6 - 6,35