

GSXG 2531

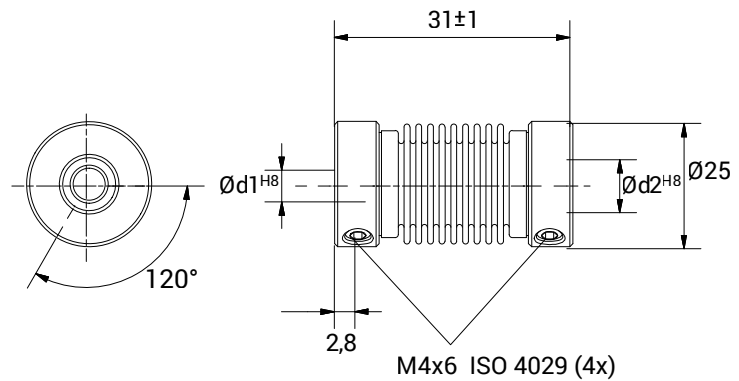

CHARACTERISTICS

- Coupling obtained from two anodized aluminium hubs with special steel bellows.
- Unique misalignment correction capacity.
- High torque rigidity.
- Backlash and vibration free.
- Outstanding servo control.
- Screw fixing system.



TECHNICAL DATA		
Maximum speed	min ⁻¹	10.000
Maximum torque	Nm	2
Radial misalignment max.	mm.	± 0,35
Axial misalignment max.	mm.	± 0,45
Angular misalignment max.	degree	± 4
Torsional stiffness	Nm/rad	183
Radial stiffness	N/mm	17,8
Moment of inertia	gcm ²	20
Clamping torque max.	Ncm	150
Working temperature range	°C	-40/+140
Weight	g	18
Hubs material		Anodised aluminium
Bellow material		Stainless steel

DIMENSIONS		
External diameter	Ø	25
Length	mm.	31
Screw position	mm.	2,8
Screw thread		M 4x6
Standard hole combinations d1 H8 / d2 H8	mm.	6/6 - 6/8 - 6/10 - 6/12 - 6/14 - 6/16 8/8 - 8/10 - 8/12 - 8/14 - 8/16 - 10/10 10/12 - 10/14 - 10/16 - 12/12 - 12/14 12/16 - 14/14 - 14/16 - 16/16