

# GSXG 1924



## CHARACTERISTICS



- Coupling obtained from two anodized aluminium hubs with special steel bellows.
- Unique misalignment correction capacity.
- High torque rigidity.
- Backlash and vibration free.
- Outstanding servo control.
- Screw fixing system.

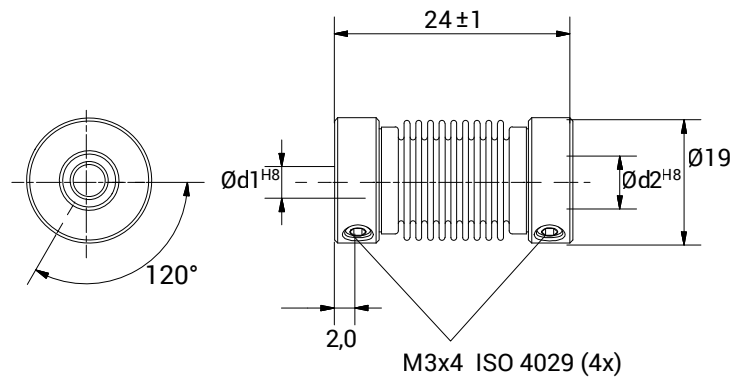

TECHNICAL DATA		
Maximum speed	min <sup>-1</sup>	10.000
Maximum torque	Nm	1,2
Radial misalignment max.	mm.	$\pm 0,25$
Axial misalignment max.	mm.	$\pm 0,4$
Angular misalignment max.	degree	$\pm 4$
Torsional stiffness	Nm/rad	150
Radial stiffness	N/mm	25
Moment of inertia	gcm <sup>2</sup>	7
Clamping torque max.	Ncm	80
Working temperature range	°C	-40/+140
Weight	g	10
Hubs material		Anodised aluminium
Bellow material		Stainless steel

DIMENSIONS		
External diameter	$\varnothing$	19
Length	mm.	24
Screw position	mm.	2
Screw thread		M 3x4
Standard hole combinations d1 H8 / d2 H8	mm.	3/3 - 3/4 - 3/5 - 3/6 - 3/6,35 - 3/8 3/10 - 4/4 - 4/5 - 4/6 - 4/6,35 - 4/8 4/10 - 5/5 - 5/6 - 5/6,35 - 5/8 - 5/10 6/6 - 6/6,35 - 6/8 - 6/10 - 6,35/6,35 6,35/8 - 6,35/10 - 8/8 - 8/10 - 10/10